

MJERILO, PRAVOKUTNA PROJEKCIJA I KOTIRANJE

Prema prostornom crtežu geometrijskog tijela i zadanom pogledu nacrtaj pravokutnu projekciju u M 1:1 i u M 2:1, Pravokutne projekcije iskotiraj!
PAZI NA VRSTE CRTA U TEHNIČKOM CRTANJU!!!

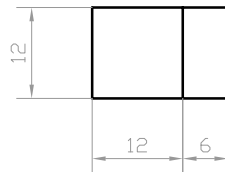
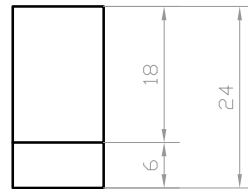
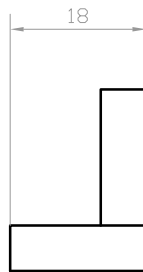
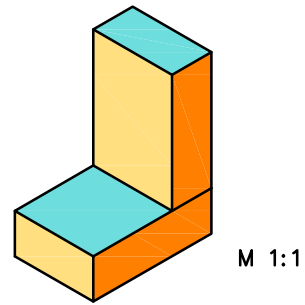
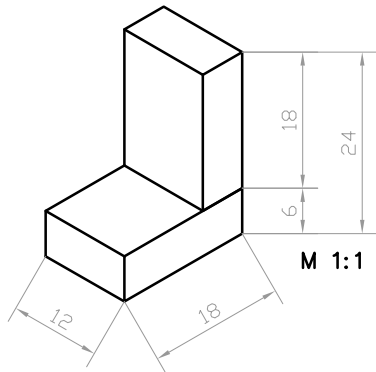

M 1:1

UVEĆANO MJERILO

PRIRODNA VELIČINA x 2

Crtamo:

d = 18 mm jer je $36 \times 2 = 64$

š = 12 mm jer je $12 \times 2 = 24$

v = 24 mm jer je $24 \times 2 = 48$

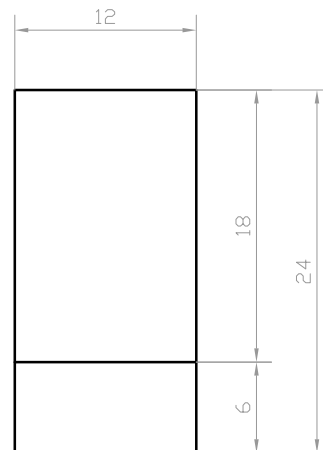
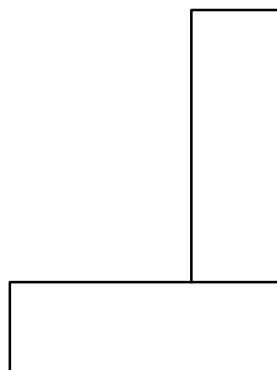

M 2:1

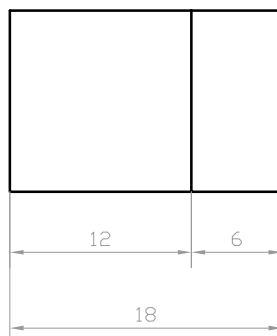

KOTIRANJE

U kojem god mjerilu crtamo (umanjeno ili uvećano) kotni broj na kotama uvijek predstavlja prirodnu odnosno stvarnu veličinu. Primjeti kako je kotni broj dimenzije u prirodnoj veličini jednak u uvećanom mjerilu.